

# 110V AC

# 12V DC

ATT \_ SPECIFICATIONS SUBJECT TO CHANGE WITHOUT NOTICE.

\_ TB = TERMINAL BLOCK.

----- DC NEGATIVE LINE

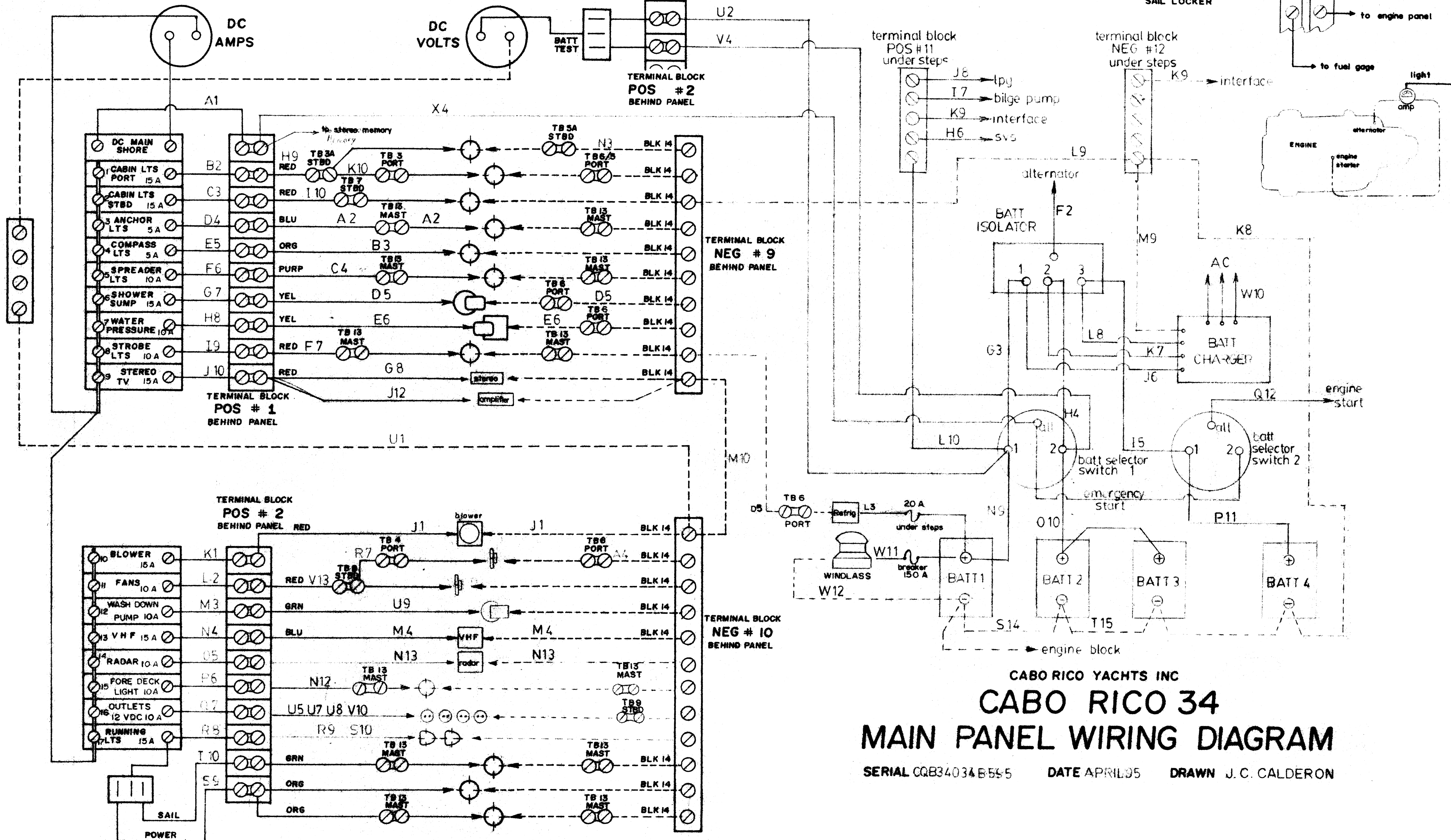
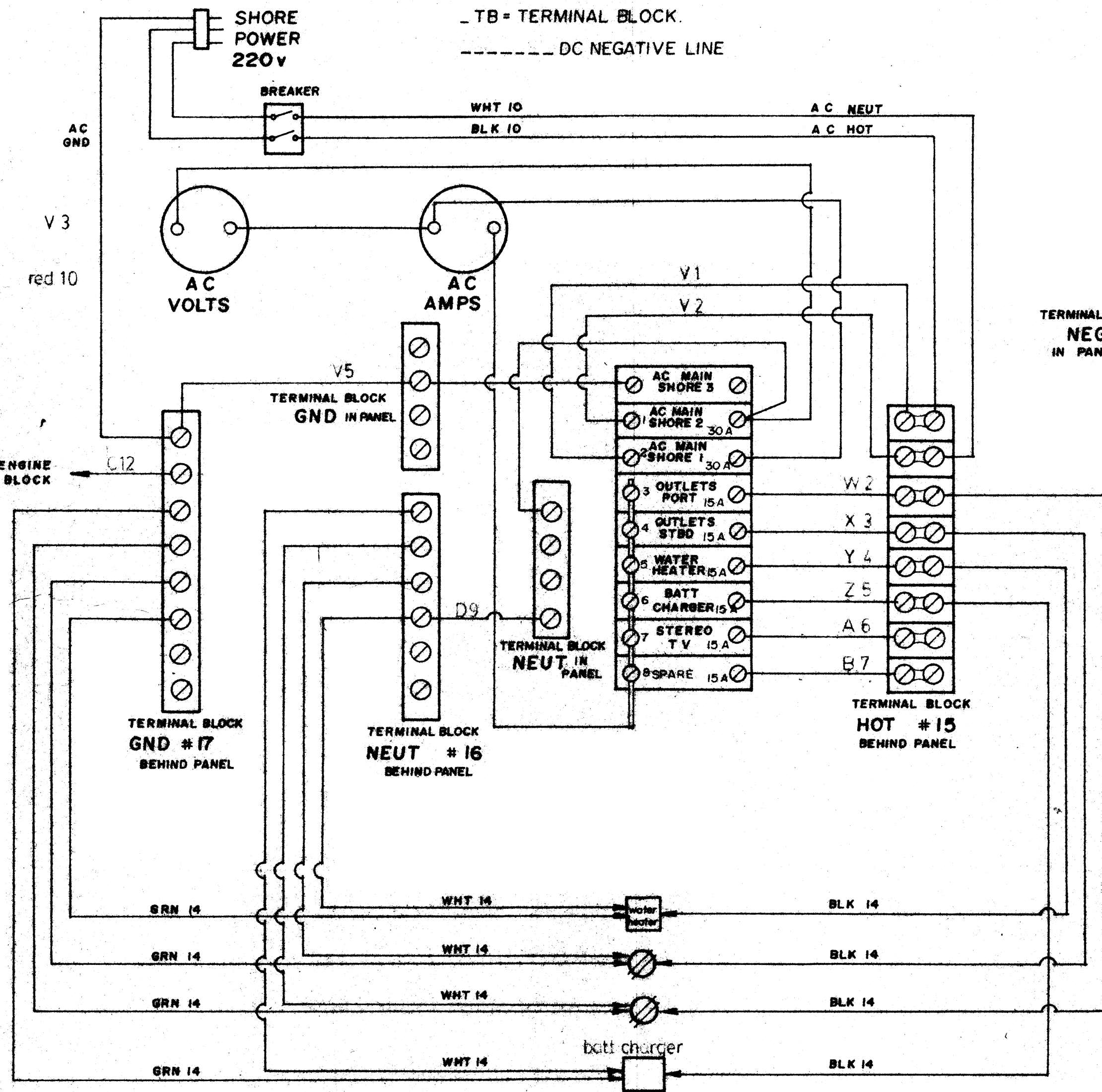

CABO RICO YACHTS INC  
**CABO RICO 34**  
**MAIN PANEL WIRING DIAGRAM**  
 SERIAL CQB34034 B555 DATE APRIL 95 DRAWN J. C. CALDERON